



CONESTOGA CABINET ASSEMBLY INFORMATION

We suggest you view the **4 minute assembly demonstration video** on our web site to see how easily our high end custom cabinets are assembled.

Before continuing, it is important to realize that Conestoga's RTA cabinet is targeted at cabinet shops who would rather use this system than build their own custom cabinets from scratch. On one hand, this indicates that it's a VERY high quality cabinet. On the other hand, it means Conestoga has made some assumptions that its user has certain level of cabinet making skills and knowledge which most homeowners may not possess. As a result, we feel the assembly instructions Conestoga details in their guide are incomplete. Therefore, we have compiled the following assembly information from our years of assembly experience with this product. Remember, as opposed to other Conestoga Re-sellers or sales agents, we actually use the product every day. So, if you have a question that is not answered here, just give us a call and we can talk you through it, send you images from our shop floor, diagrams or even helpful hardware items to assist you. If it gets frustrating, take some time away and give us a call or shoot us an email. Rest assured, we'll get you through it!

What is Included with Your Cabinets:

- Everything necessary to build the cabinet box.
- Drawer glides and necessary hardware/screws.
- Hinges and necessary hardware/screws.
- Doors, drawer fronts and drawer boxes.

What is not included with Your Cabinets:

- Screws required to mount drawer fronts to the drawer boxes (we use self tapping wood screws 1-1/4" long, available at local home centers or hardware stores. Standard wood screws work fine too).
- Screws for cabinet installation (We use 2-3/8" torx head wood screws for joining cabinets 'face frame to face frame'. Pre-drill and lubricate the screws with wax or dish soap to avoid snapping them off. We use 3" heavy duty screws for mounting cabinets to wall).
- Plastic or cork Door bumpers (Readily available at Lowes or Home Depot)
- Knobs and handles
- Jigs for installing knobs/handles, aligning doors/drawer fronts, etc.

- Glues or adhesives
- Double backed tape referred to in this guide for mounting drawer fronts to drawer boxes.
- Wood filler for filling nail holes, touch up kits for finish repair (touch up kits available for \$7.50. filler can be purchased at a home center).

Tools Required

- Pneumatic nail gun and compressor – Preferably 18 gauge with 1-1/4" pins – Available at most tool rental facilities.
- Wood glue – Titebond II is an excellent choice and available at any home improvement store, but any wood glue will suffice. Do not use Gorilla Glue or similar 'foaming' glues as they make a horrific mess.
- Rubber mallet or padded 'dead blow' mallet.
- Wet rag (to wipe off excess glue drips)
- Drill gun with Phillips bit (for installing drawer glides, hinges, etc)
- Screwdriver (Phillips head)
- You may want to use some cabinet clamps to assist as a second set of 'hands' on certain odd shaped cabinets, but this is not a requirement. Available at any home center.
- A flat work surface that you can walk around. A work bench against a wall is not typically suitable as you can't work from both ends of the cabinets. A low table formed from a sheet of plywood elevated on some cinder blocks would work fine.

Packaging

- As a general rule, Conestoga 'over-packages' everything due to the expense and fragility of finished wood products. This results in a remarkably low damage rate, but it also means that you need to dispose of a lot of packaging materials. The packaging consists mostly of cardboard, plastic strapping, thin paper or foam sheeting and wooden pallets. Be sure to plan your workspace and disposal needs accordingly.
- All cabinets will be packaged in their own carton with the cabinet description clearly labeled on the end of the box. Some cabinets will come in several boxes. For instance, a tall pantry cabinet would come with the shelves and other items packed in a separate box. Such cabinet boxes will be labeled '1 of 2', '2 of 2', etc. Each cabinet box will have everything you need to assemble the basic cabinet box. *Please note that the plastic splines detailed in the video are packed in a separate hardware box, so before beginning your assembly, locate this hardware box!*
- Cabinet doors are packaged separately and are NOT marked for a given cabinet. You will need to unpack all your doors and match them up with the cabinets. A spreadsheet that details the door sizes for your cabinets can be found in our 'downloads' section of our site if you need it, but this is generally not necessary as the doors are easily matched up with the cabinets using *the cabinet quote we*

supplied to you. Each door/drawer on the paperwork has its corresponding cabinet noted to the right of it.

- Drawer boxes come assembled and finished and are strapped to their own pallet and wrapped in cardboard. As with the doors, a spread sheet is available in the 'downloads' section, but this is generally not necessary as drawer boxes are also noted on your quote paperwork with their corresponding cabinet.
- Moldings and other parts and pieces will come in their own boxes.
- All items will be shipped on pallets, so access to a forklift and/or loading dock is helpful, but not required. Please see the 'POLICIES' section for more on shipping.

Getting Set Up for Assembly

- We recommend that you assemble a cabinet at a time. If you begin unpacking all the cabinets, it will be easy to confuse your parts and pieces.
- Ensure you have a flat, padded work surface. The floor of a garage is satisfactory, but bending over may become tiresome. A low, solid table may be ideal.
- Assembled cabinets take up a bit more space than the flat packed ones! Be sure to plan where you will store your 'work in process.'
- Pick a small, easy cabinet first and dry fit it together (no glue or pins) to get the feel for the assembly process. Once you feel you have it down, slide the cabinet apart, get your nail gun/compressor, glue and rubber mallet handy because you are ready to start assembling your dream kitchen!

Now that you are set up and ready to go, proceed to the next page to begin assembling your first cabinet!

Assembling Your Cabinets

While there are some slight differences in assembly between a wall cabinet and a base or tall cabinet, the principles are the same. Again, before reading these instructions, watch the assembly video found at http://www.thecabinetjoint.com/video_new.asp and locate your hardware box that has the black plastic splines necessary for assembly.

1. Choose a simple cabinet like a standard base or wall cabinet. Don't start with a corner cabinet or pantry as you will want some experience with the product before you tackle one of the more demanding units. Its even a good idea to try a 'dry assembly' before pinning and gluing one together. However, do note that they are tough to get apart, even when no glue and pins are used.
2. Start with the face frame laying face down on a padded surface. The Conestoga assembly guide, downloadable from our website, details a slightly different 'face up' approach. The basics of assembly are the same, but we like the face down approach better because you achieve a tighter cabinet with fewer gaps and because you are assembling into the finished face frame rather than smacking the finished face frame with a hammer as is the case with the Conestoga 'face up' method. Years of experience tells us this is the most efficient and trouble free method and that is what we will detail here. However, feel free to use either method as it suits your needs. Should you decide to proceed with the face up assembly, you will require an assembly jig which can be purchased for \$25.
3. Lay a bead of glue in the cabinet face frame groove. You will see that there is a wide groove (dado) and then an 1/8" deeper groove in the center of it. Your glue bead will be on the two 'shoulders' of the wide groove. Do not use too much glue or it will squeeze out onto the finished surfaces and will create a mess to clean up. With white glue, more is not always better. See the video for details on this step.
4. The 3" long splines are placed evenly about 3" apart on the left and right stiles and the cabinet top, bottom and fixed shelf rails (tall cabinets have a separate middle 'shelf' that is fixed to the cabinet face frame- these areas need splines in the frame to hold the face frame to the fixed shelf). The 3/4" splines are placed at all 4 corners of the cabinet front frame. DO NOT place any of the 3" splines in line with any horizontal cabinet frame rail as this will inhibit the cabinet top, bottom or fixed shelf from fully nesting into the cabinet front frame.

Insert your black plastic splines into the deeper groove with the 2 fins of the spline in the face frame groove. Press the spline firmly until it is fully seated in the groove. Also ensure that the spline is straight up and down, not tilting left or right.

5. Place your cabinet sides onto the front frame by aligning the splines in the face frame with the deep groove in the front edge of the cabinet side. Tap the cabinet side into the face frame until the side is firmly seated against the face frame. Inspect all around the frame to ensure it is seated everywhere.

IMPORTANT NOTE: Be sure you have the left and right sides of the cabinet correctly placed. This is critical on wall cabinets with extended stiles and finished ends because you could accidentally build the cabinet with the extended stile and the finished cabinet end on the same side! It is virtually impossible to get the cabinet apart once the glue sets, so pay attention as you assemble the cabinets!

6. Run a bead of glue about half way down the top and bottom dovetailed groove found in each cabinet side.
7. Place your cabinet top/bottom into the dovetailed cabinet groove so that the notched end is facing up (towards the back of the cabinet), the grooved edge is facing down (towards the front frame) and the finished side of the panel is facing the interior of the cabinet.
8. Using even pressure (and your rubber mallet if necessary), press/tap the cabinet top or bottom down until the splines insert into the groove on the face of the top/bottom panel. Be sure that the top/bottom slides down evenly on the left and right or it may bind and no longer slide.

You may need to engage the side panel with the splines by using some sharp hits with the mallet. If you find the panels do not slide into the dovetailed groove easily, some light sanding of the dovetails will help immensely. Once this step is complete, there should be no gap where the face frame meets the top/bottom panel.

9. Once the top and bottom are installed, its time to insert the cabinet back. Simply slide the cabinet back into the 1/4" groove in the cabinet sides until it seats in the notches in the cabinet top and bottom installed in step 7 above.

IMPORTANT NOTE FOR WALL/TALL CABINETS: You will immediately see that the back can't be slid into the groove in the cabinet sides because the cabinet top and bottom completely cover it. Simply hold the cabinet side firmly and tap the top (or bottom) downward until it just begins to push the face frame off of the cabinet sides (see fig. 1 below). Do not overdo it! You only need to push it off by about 1/4", just enough for the back groove in the cabinet sides to be accessible (indicated by red circle in fig. 2 below). Slide the 1/4" cabinet back all the way in and seat it on the notch in the cabinet top/bottom. Then tap the cabinet sides back on to the face frame until they are once again firmly seated against the frame (see fig. 3 below). As you do this, you will see that the cabinet back will nest into the notches on both the cabinet top and bottom.



Fig 1



Fig 2

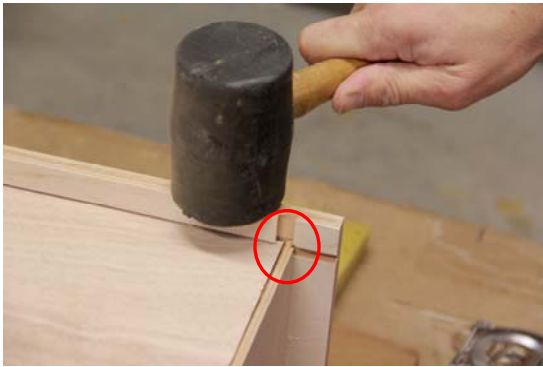

Fig 3

10. Once the back is fully inserted, lay a wavy bead of glue on the cabinet back that extends no more than 2 inches down from the top/bottom.
11. Insert the cabinet hanger cleat by sliding the 'ears' into the cabinet back groove and pressing the cleat inward until it laps over the glued area. You will know the cleat is in place when the thin routed 'nail line' on the back of the hanger cleat lines up with the dovetail in the cabinet side. The video illustrates this step very well.
12. Using your nail gun, place a 1-1/4" finish nail about every 3" along the nail line in the hanger cleat. Be certain that the nail gun is straight up and down before driving the nail in as the nail may protrude into the cabinet interior if care is not taken.

OPTIONAL RECOMMENDED STEP: Again using your nail gun, place a finish nail in the side of the cabinet into the ends of the hanger cleats (both top and bottom). This step will lock the cabinet sides to the hanger cleat. On finished ends, simply place a little color matched wood filler in the nail holes.

OPTIONAL RECOMMENDED STEP: Using a hot melt glue gun, run a thin bead of hot melt on the back of the cabinet where the cabinet back meets the cabinet side and another bead on the cabinet top and bottom where the top/bottom meet the face frame. This will keep the cabinet back from sounding 'loose' and keep the cabinet face frame tight to the top and bottom in the event the splines loosen over time.

FOR BASE CABINETS: Base cabinets use spreader strips instead of a full top. For easy reference as to how these are installed, watch the assembly video found on our website.

FOR SINK CABINETS: You will notice that sink cabinet ship with two loose plywood scraps that measure roughly 3 x 5. These scraps are mounted to the BACK of the front frame with screws (not provided) at the extreme left and right sides of the opening. This then provides you with ample 'real estate' to screw through this plywood and in to the back of the drawer front. They are not required and in fact, we do not use them in our own installations (we simply screw through the back of the frame into the back of the drawer front), but in some cases, as with inset drawers or partial overlay drawers, they simplify things greatly.

FOR TALL CABINETS: You will notice on some tall cabinets, there are 2 cabinet backs and a center 'fixed shelf' that looks a lot like a top and bottom. The fixed shelf is different in that it has a double notch instead of a single notch since it is capturing both cabinet backs. Assemble the tall cabinet like a wall cabinet and then slide the backs in from either end until they both meet at the notches on the fixed shelf.

CORNER PIE CUT WALL AND BASE CABINETS: These cabinets generally require two people to assemble. We recommend that you read the assembly instructions for these cabinets that can be downloaded from this web site. It is critical to note that the SHELF MUST BE INSTALLED IN THE CABINET AS IT IS BEING ASSEMBLED! The shelf cannot be inserted through the cabinet opening once the cabinet is assembled. See the steps and figures below for guidance on these cabinets.

- 1. Lay a cabinet side flat on the work surface and then glue both dovetails as you would with any other cabinet.*
- 2. Slide the top and bottom in to the cabinet side, getting them as close to final position as possible, although this is not critical at this point.*
- 3. Lay the cabinet on its face as shown below. Glue the second cabinet side and slide it onto the top and bottom dovetails as shown in the figure below. Again, push the side all the way into position, but do not be concerned with exact placement in the dovetails as we will do this in the next step.*



4. *Glue the face frame shoulders and insert the splines into the 2 face frame pieces as with any other cabinet frame.*
5. *Tap the face frames on to the cabinet box, being careful to align things properly. See figure below.*



6. *Once the face frame is installed, tap the cabinet top/bottom into place and seat them tight against the back of the frame. See circled area in Figure below.*



7. *Now install your shelf!*



8. *Lay the cabinet on its face on your padded surface. Install one cabinet back and carefully pin it to the cabinet top and bottom. This will keep the top and bottom from moving while you complete the back assembly. See the figure below.*



9. *Glue the diagonal back piece and Insert the splines in the top and bottom grooves. Place it on top of the cabinet back and work the already installed cabinet back into the back groove. Lightly tap the back piece into position, but do not fully seat it.*



10. *Carefully work the second back into position, inserting it into the back groove in the corner back piece you just installed. Once both backs are seated fully in the corner back piece, tap it hard on to the back of the cabinet to seat the splines. Then, pop a couple nails in through the angled piece into the cabinet top and bottom. This will hold things in place while glue dries and while you work on the hanger cleats.*
11. *Install the 4 hanger cleats as you would with any other cabinet: A wavy line of glue, insert the hanger rail and then pin it to the cabinet along the scribe line.*

Without going in to great detail, angled corner cabinets such as the BCFD and WCS cabinets go together much the same, except for the first few steps:

1. *Lay the face frame on the work surface and glue it/insert splines as normal.*
2. *Insert the TOP and BOTTOM into the face frame (this is the opposite of a normal cabinet where the sides go on first).*
3. *Glue the cabinet side dovetails and then slide them onto the installed cabinet top/bottom until they fully seat against the back of the cabinet frame.*
4. *At this point, you may follow the same instructions as for the pie cut cabinet from steps 7-11.*

Now that your cabinet box assembly is complete, move to the next page for instructions on 'fitting up' the cabinet with doors, drawer boxes and drawer fronts.

Installing Your Hinges and Doors

1. Place a hinge in the circular routed cup of the door and screw it to the door frame with the provided wood screws as shown below:



2. Once all hinges are installed in the door, hold the door to the cabinet face frame and align it according to the diagram below.

1/2" Overlay

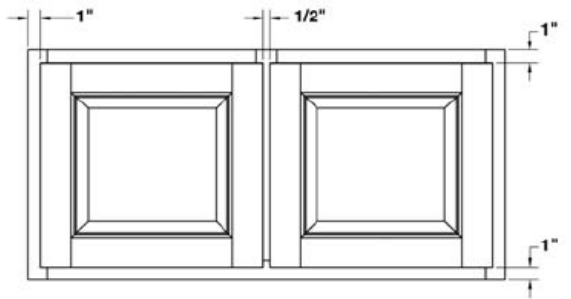

1-1/4" Overlay

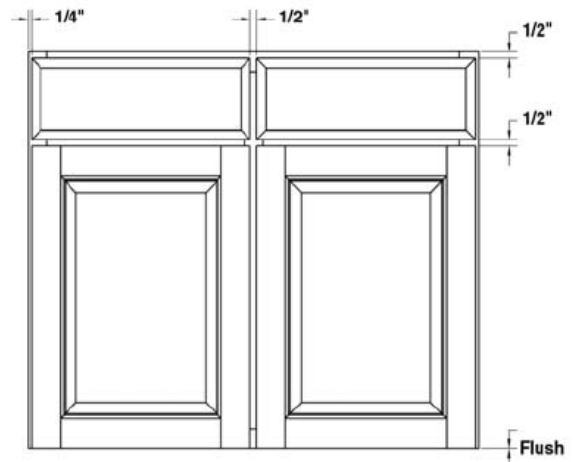
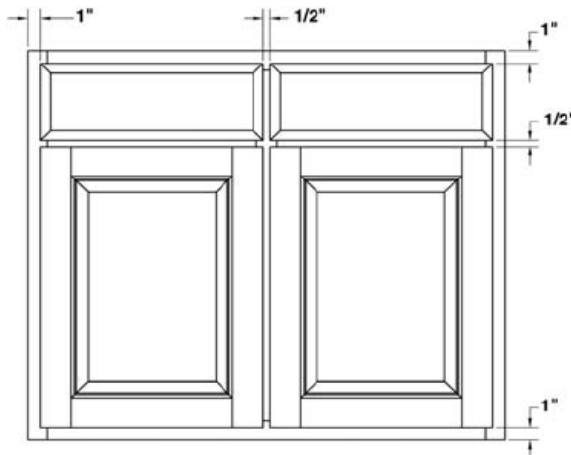
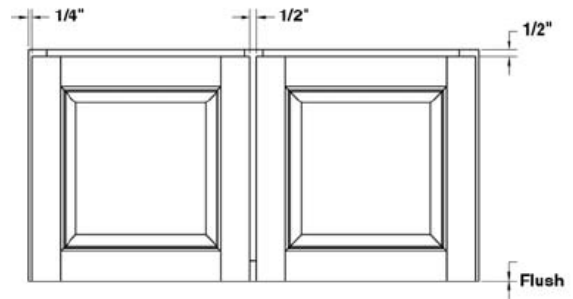

3. Place a screw (provided with hinge pack) through the slotted hole in the hinge and drive it into the face frame edge until snug. Do not over tighten or you may strip the hole. We recommend final tightening be done with a hand screw driver versus the drill. **DO NOT PREDRILL** these holes! It is best to drive the screws into virgin wood to ensure they remain tight. If you choose to pre-drill, use no bigger than a 1/32" drill bit.
4. You can fine tune the adjustment of the door by using the two screws on the hinge body. One adjusts the in/out motion of the door while the other controls the left/right motion of the door. If you wish to move the door up or down, you need to loosen both screws that hold the door to the frame and slide the door up or down, retightening the screws once the door is in the proper position. Play with the adjustment screws to get the doors perfectly aligned. However, final adjustments should be completed **AFTER** your cabinet installation as the installation process will cause the doors to move/rack. In fact, *we strongly recommend that all door and drawer front up-fitting be completed after the cabinet installation to ensure that the doors/fronts are not damaged due to construction related activities.*
5. Some doors will use **odd overlay hinges**. For instance, even if you ordered full overlay cabinets, diagonal corner cabinets use 1/2" overlay hinges. Similarly, any doors that share a common face frame member will be 1/2" overlay. This is common on many of the combination vanity cabinets.

Installing Your Drawer Glides

1. Your cabinet order should have included an installation jig for either Blum Tandem or Blum Solo glides. These jigs are included automatically for full kitchen orders and may be chargeable on smaller orders. The jigs cost \$25. The jigs are slightly different, so you must use the correct one. The images shown in the rest of these instructions show the Blum Tandem installation as it is by far our most popular glide.
2. Stand the jig up in the corner of the cabinet as shown in the picture below (Blum Tandem mounting brackets shown inserted in this image).

Note: As an alternative, lay the cabinet on its back to install the jig/drawer glides. We find this is easier since the jig does not fall over and screws/screwdriver used in next step are easier to control.



3. Open the poly pack containing a pair of drawer glides and locate the rear brackets (metal L shaped brackets for Blum Tandem, Plastic sockets for Blum Solo).
4. Slip the rear bracket/socket into the square cut out in the locator jig as shown in the image above and secure the bracket to the cabinet back using the screws provided. In the case of bottom drawers, the bracket sits directly on the cabinet floor.
5. Remove the jig from the cabinet.
6. Slide the drawer glide on to the bracket as shown in the instructions that came with the drawers and set the front of the drawer glide on the bottom frame

member of the face frame opening. For Blum Tandem Soft Close, the front of the drawer glide should be set back 3/16" from the *front* of the face frame. For Blum Solo glides, the front of the glide should be flush with the front of the face frame. See the Inset instructions later in this guide for some differences in inset drawer glide installation.

Properly installed drawer glides (Blum Tandem Shown)....



7. Secure the glide to the cabinet face frame with a flat head wood screw provided with your drawer glide hardware.
8. For Blum Tandem glides, install the orange release handles in the front corners of the drawer box per the provided directions.
9. For Tandem glides, set the drawer box on the drawer track and slide the box into the cabinet on the tracks until it clicks into place.
10. For Blum Solo, install the under mount rails to the bottom lip of the drawer box per the included directions (see image below). The roller goes to the back of the drawer box where the notch is located.



11. For Blum Solo, place the drawer box into the installed drawer glide by overlapping the rollers (need to keep the drawer box tilted downward as you do this) and then tilt up and slide in to the drawer track, ensuring that it rolls smoothly.

Installing your Drawer Fronts

NOTE: We strongly advise that the doors be mounted before the drawer fronts are affixed as this is critical to achieving proper door/drawer front alignment.

We recommend an easy and unique method of installing your drawer fronts, again borne out of our experience in assembling hundreds of these cabinets per month.

1. Go to Lowes and procure a package of Scotch double backed tape made by 3M. See the package picture below. This product comes in either rolls or pre-cut squares. The choice is yours as either work well, but we like the rolls because you get more for your money.



2. Place a square of the double backed tape in the corner of each drawer box (drawer box should be installed in the cabinet at this point). Peel off the green backer to expose the adhesive facing.
3. With the drawer in the closed position, align the drawer front and press it firmly onto the drawer box face. The double backed tape will hold the drawer front in place quite nicely while you secure it permanently in step 4. If the drawer is not aligned just the way you like it, pull firmly to remove it and then repeat this step until you get the alignment the way you want it.

TIP: For 1-1/4" overlay drawers, place a piece of 1/2" scrap wood (a small piece of toe board material works well) on top of the door edge to use as a spacer. Set the drawer front on top of the scrap spacer and move to step 4. This will assist you in automatically achieving the required 1/2" between the door and the drawer front above it. The same trick can be used when installing drawers in a stack, one on top of the other.

4. Open the drawer box and then place a 1" or 1-1/4" wood screw (not provided) in the far left and right hand interior corners of the drawer box and screw through the drawer box into the back of the drawer front (see image below). It is CRITICAL that your screw be placed in such a way as to gain purchase in the left and right framing member of the drawer front. To achieve this, you may need to drive these screws at an angle as shown. If installing a tall drawer, we suggest you use 4 screws to secure the drawer front (one in each top and bottom corner). You can also drive the screws into the back of the raised panel, but be careful with your placement as you could accidentally come through the face of the drawer panel in the panel raise area. For flat panel drawer fronts, do NOT try to screw into the back of the panel. The panel is too thin to provide adequate screw purchase and furthermore, you risk running the crew though the face of the drawer front. As a last resort, plastic clips can be purchased through fine on line retailers such as rockler.com, but we have yet to have to resort to this.



5. Once you install your drawer front decorative hardware (knob, pull, etc), this will further secure the drawer front to the drawer box as the hardware screw will pass through the drawer box (may need to purchase longer screws for your hardware

for this step). If your drawer front design uses a flat plywood panel, there will be a recess on the back of the drawer front. You may wish to install a shim behind the panel so that as you tighten the screws that hold your hardware on, you do not buckle the thin plywood panel.

TIP: As opposed to other Conestoga re-sellers who recommend installing the hardware before installing the drawer front, we strongly advise installing the hardware AFTER the drawer front is mounted so that the motion and stress of pulling the drawer open is carried through the drawer box itself. Otherwise, this stress is carried by the drawer front only which may result in loosening of the drawer front/drawer box juncture or even its complete failure over time.

General Tips for Inset Cabinets:

1. When installing drawer glides for inset cabinets, you will receive mounting brackets for the drawer glides. See diagram below.

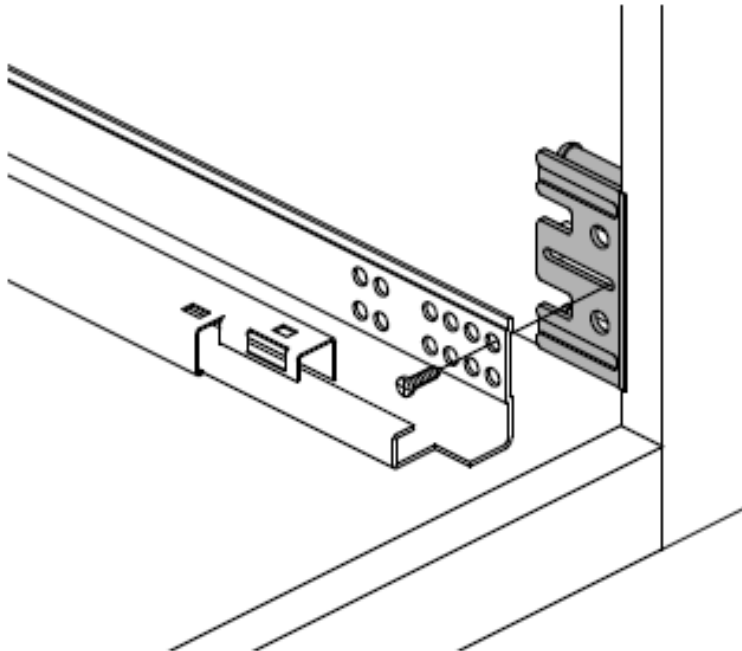

These brackets are necessary because the drawer glide does not sit on the face frame as in the overlay instructions discussed earlier because the inset drawer front occupies this space. The glide actually mounts inside the cabinet and therefore it needs to be anchored to the cabinet wall.

2. We recommend installing the hinge bracket for your inset door to the face frame **BEFORE** cabinet assembly. It is possible to do it after assembly, but requires you to work inside the cabinet and is a fairly clumsy and time consuming process. For installing inset hinges and clipping the door to them, follow the instructions included with your inset hinges. Below is a diagram of the inset hinges as viewed from inside and outside the cabinet.

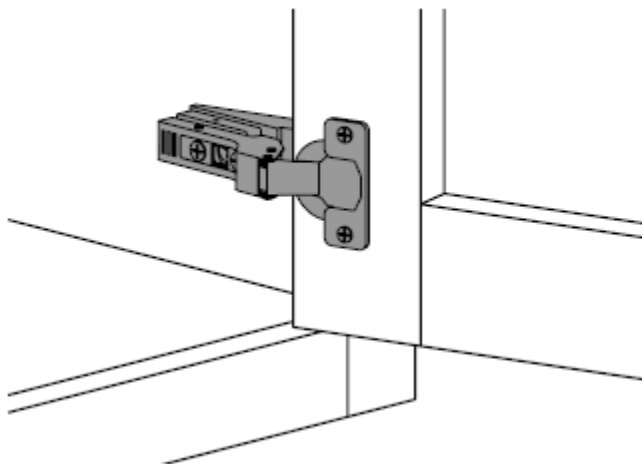
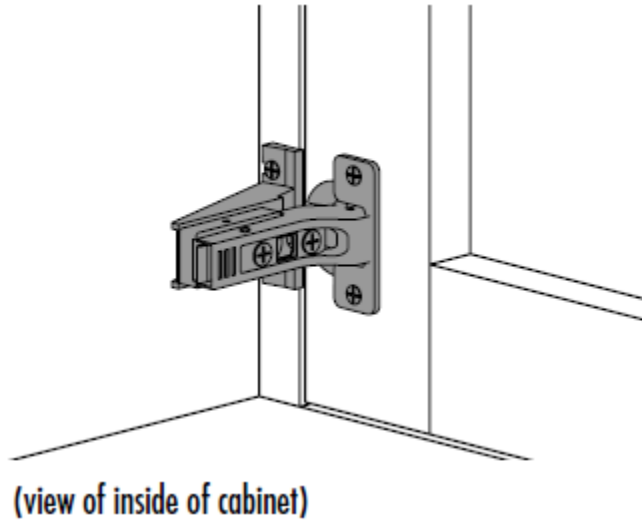

3. When fitting the doors and drawer fronts, an 1/8" gap must be maintained between the frame and the door/drawer front. 1/8" shims (a scrap piece of paneling is ideal) will work as an ideal spacer to ensure that you attain the proper clearance between doors and frames.
4. While not included, a magnetic latch may be ideal for ensuring that cabinet doors stay flush with the face frame. Wood **WILL** move over time and you may see the corner of the door protruding from the inset frame slightly. This is not considered a defect and will need to be controlled by the use of such magnetic latches.

5. Inset cabinet frames are made with a specific door(s)/drawer fronts sized for them. If you find that a door or drawer front is not sitting correctly in an opening, try to locate another door/drawer of the same size as you probably have the wrong door. Each door/drawer front is squared to its frame opening, so you should have consistent gaps of ~1/8" between the door/drawer front and the frame. As an aid, Conestoga labels each frame and its doors with a number. Simply match up the number on the edge of the door/drawer front with the number shown on the back of the face frame (stamped in red).

Congratulations on the purchase and successful assembly of your fine Conestoga cabinets. They will provide years of trouble free service while simultaneously creating an elegant design statement in your home and increasing its value. When your friends ask you 'who built your kitchen?', take note of their expression when you tell them 'I did it myself!'

Thanks for becoming part of the Conestoga and Cabinetjoint.com family and call us with any questions you may have on your assembly.